



Addendum #1

Project: Treated Water Pipeline – MCWC East Service Line

Bid Date: 2:00 P.M., Local Time, **June 20, 2017**

Bid Location: Lewis & Clark Regional Water System Office
46986 Monty Street, Tea, SD 57064

Issue Date: June 14, 2016

Notice: Failure to acknowledge all addenda in the BID may cause rejection of the BID. See Instructions to Bidders.

SCOPE OF THIS ADDENDUM:

The following becomes a part of the original project manual and drawings, taking precedence over the items that may conflict. The bidder shall note receipt and make acknowledgment of the Addendum on his/her bid form, incorporating its provision in his/her bid.

PRIOR APPROVALS:

The following manufacturers of the items and materials have been added to the list of approved manufacturers. Listing of an item does not change the requirements of the specifications. Equipment furnished shall meet the materials and performance requirements as specified.

None

PROJECT MANUAL:

The following additions, changes and clarifications have been made to the Project Manual.

Section 00800 – Supplementary Conditions – ADD SC-5.01.D “Contractor shall meet the requirements for the City of Sioux Falls Contractor Bond and General Liability Insurance as per the attachment”.



DRAWINGS:

The following additions, changes and clarifications have been made to the Drawings.

Drawing Sheet 25.

DELETE the previous Sheet 25 dated 5-30-17, and REPLACE with the attached Sheet 25, Rev. No. 1 dated 6-13-17 in its place.

NOTE:

The Plan Holders List and Addendums are available on our website at <http://www.bannerassociates.com> by clicking on the View Bid Information/Project Name/Project Information link.

Project Manual and Drawing inquiries regarding the work should be directed to:

Contact Persons:

BANNER ASSOCIATES, INC.

Sioux Falls Office Scott Vander Meulen Phone - (605) 692-6342 or 1-855-323-6342 FAX – (605)-692-5714 E-mail - scottvm@bannerassociates.com	Brookings Office Tim Conner Phone - (605) 692-6342 or 1-855-323-6342 FAX – (605)-692-5714 E-mail – timc@bannerassociates.com
--	---



ATTACHMENTS

1. City of Sioux Falls Contractor Bond and General Liability Insurance
2. Drawings – Sheet 25



Scott Vander Meulen, PE, LS
#6013

Contractor Bond and General Liability Insurance

The amount of your insurance must be as follows.

City Insurance Requirements

1. Workers' compensation insurance providing the statutory limits required by state law;
2. Commercial general liability insurance coverage issued by an insurance company authorized to do business in this state covering the work and activities proposed to be done in those public places.
 - a. The insurance shall provide occurrence form contractual, personal, injury, bodily injury and property damage liability coverage with limits of at least
 - i. \$1,000,000 per occurrence,
 - ii. \$2,000,000 general aggregate, and
 - iii. \$2,000,000 aggregate products and completed operations. These limits may include excess liability (umbrella) coverage.
 - iv. Automobile liability insurance covering all owned, non-owned, and hired automobiles, trucks, and trailers. The coverage shall be as broad as that found in the standard comprehensive automobile liability policy with limits of not less than \$1,000,000 combined single limit each occurrence. The required limit may include excess liability (umbrella) coverage.
 - v. The insurance policy shall name the city and its representatives as an additional insured. If occurrence form insurance is not available, claims made insurance may be provided. The policy shall be maintained for three years after completion of the work; and

Bond Requirements

1. A bond must be filed in the amount of \$10,000.
2. Contractor bonds for sidewalk, driveway, sewer and water must be renewed annually if not stated as such.

Which type of bond do you need:

A. Contractor's Bond for Work Performed in Right-of-Ways

Annual contractor's bond for grading, paving, curb cuts, installing barricades, storing construction materials, installing sidewalks, and installing/repairing sewer, water, telephone, electric, or gas lines. The bond **MUST** state:

Under Sioux Falls City Ordinance §96.030: if the Principal shall faithfully perform the contract(s) in City's right-of-ways, pay all permit and other associated City fees, promptly pay all persons supplying the contractor with labor or material in the prosecution of the work provided for under the permit, and replace any defective work within a period of three (3) years from the time of completion of the project which in the opinion of the City was not installed in accordance with the required specifications.

B. Sump Pump Installer Work on Private or Public Property

Annual bond for sump pump installation. This bond can be a separate bond or a rider to the bond described above. The bond or rider **MUST** specifically state:

If the Principal shall faithfully perform the contract(s) for sump pump work, pay all permit and other associated City fees, promptly pay all persons supplying the contractor with labor or material in the prosecution of the work provided for under the permit, and replace any defective work within a period of three years from the time of completion of the project which in the opinion of the City was not installed in accordance with the required specifications.

C. Project Specific Bond for Facilities/Utilities Work in Right-of-Ways

This bond applies to those that maintain facilities in the right-of-ways like utilities repair crews, sign companies and the like. A bond is necessary for installation and repair or removal of poles, signs, and facilities, other than landscaping, in right-of-ways as well as excavation in right-of-ways. The bond **MUST** state:

Under City Ordinance §96.241: if the Principal shall: (i) faithfully perform the work under the permit and in all things comply with the ordinances, rules and regulations of the City of Sioux Falls, and any amendments thereto, including the restoration of the right-of-way to its condition prior to commencement of work under the permit; (ii) indemnify the City against any expenditure, damage or loss occasioned by the Principal's violation of the Code or failure to comply with all rules, regulations, orders, permits and other directives of the City issued pursuant to the Code; (iii) pay all compensation due to the City, including permit fees; (iv) pay the premiums for the required liability insurance policies; (v) reimburse the City of any amounts for which the Principal is liable that are not paid by its insurance; and (vi) pay any other amounts which may become due to the City pursuant to law.

It is hereby understood and agreed that this bond may not be canceled or nonrenewed by the Surety, nor shall the intention to cancel or nonrenew be stated by the Surety until thirty (30) days after completion of construction of the facilities and, notwithstanding the foregoing, shall in no case be canceled or nonrenewed by the Surety.

TYPICAL ENCASEMENT PIPE JACKING NOTES:

1. PIPE JOINTS THROUGH CASING SHALL BE RESTRAINED JOINTS, SPLINE CONNECTED HI-IMPACT PVC PIPE, FUSIBLE PVC PIPE OR APPROVED EQUAL.
2. THIS DETAIL APPLIES TO ALL STEEL ENCASEMENT PIPE INSTALLATIONS ON THIS PROJECT.
3. SEE NOTE IN SPECIFICATIONS REGARDING CASING END PLATE.

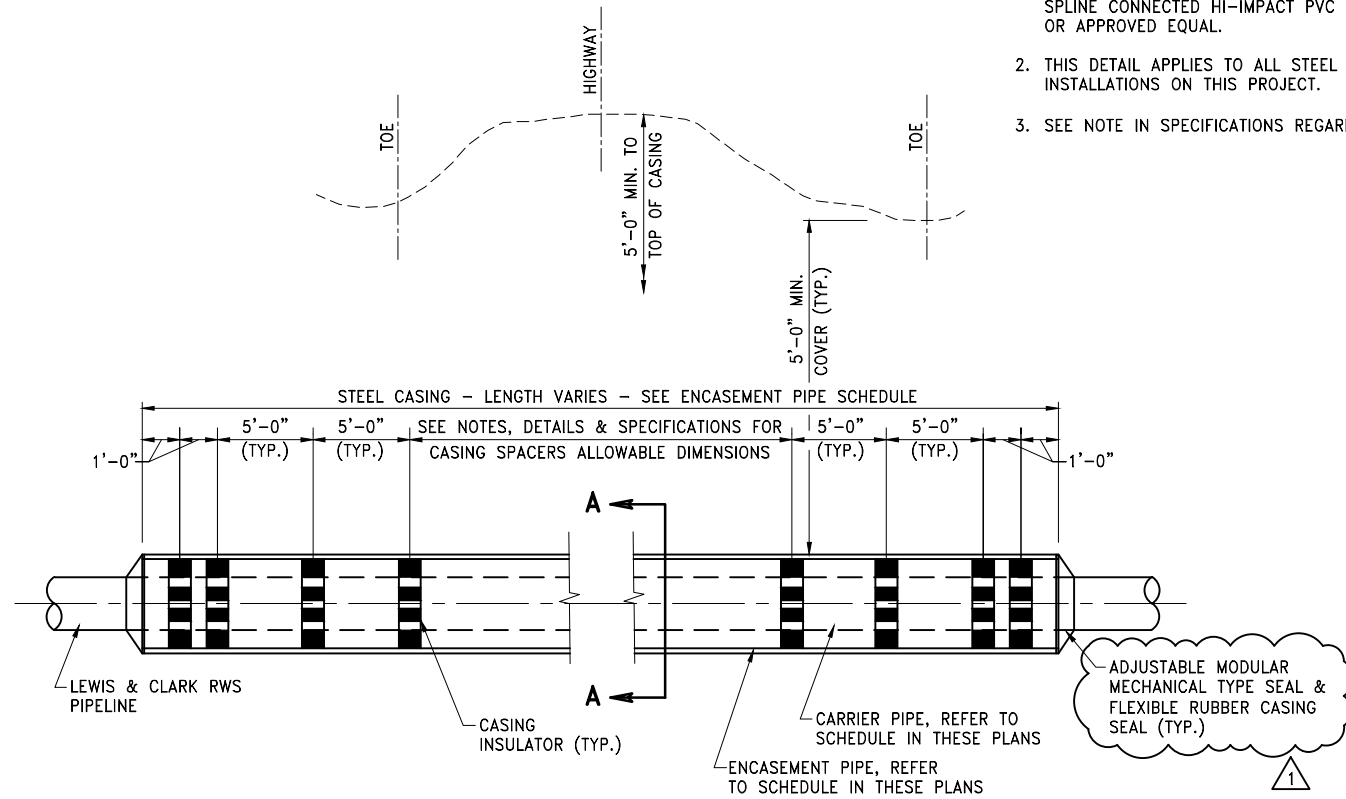

TYPICAL ENCASEMENT PIPE JACKING SECTION
NO SCALE

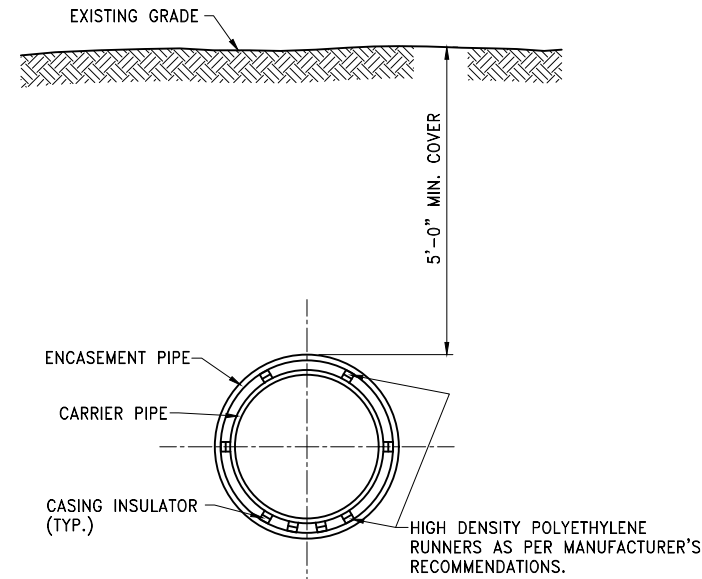

SECTION A-A
NO SCALE

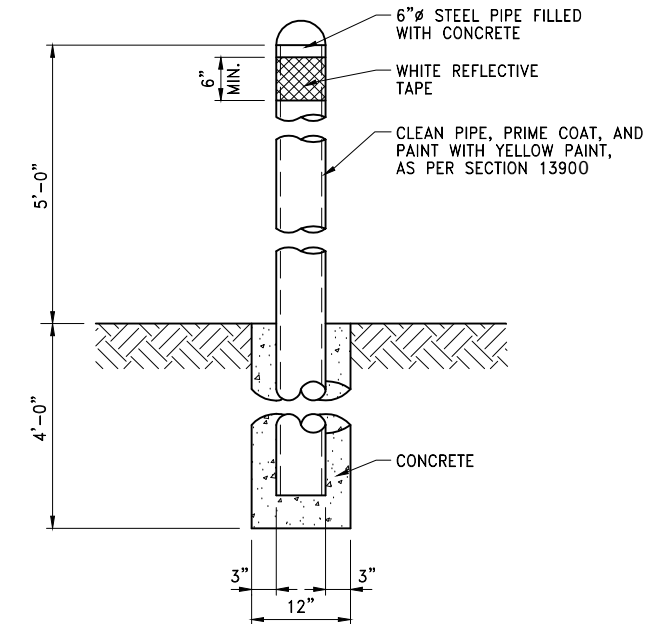

STEEL PIPE BOLLARD DETAIL
NO SCALE

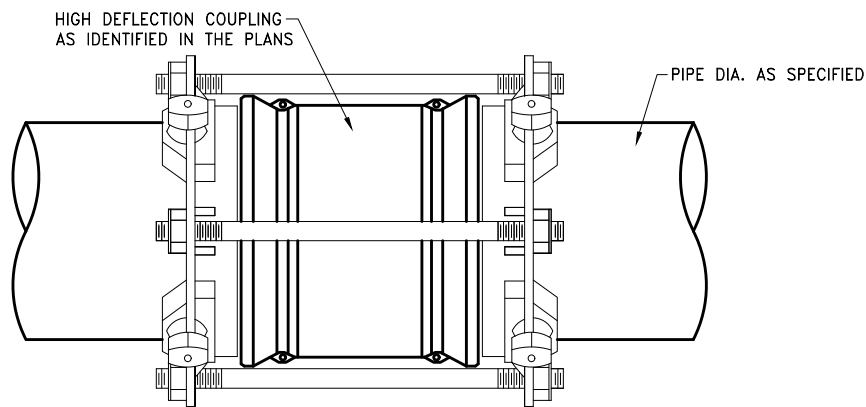

HIGH DEFLECTION COUPLING DETAIL
NO SCALE

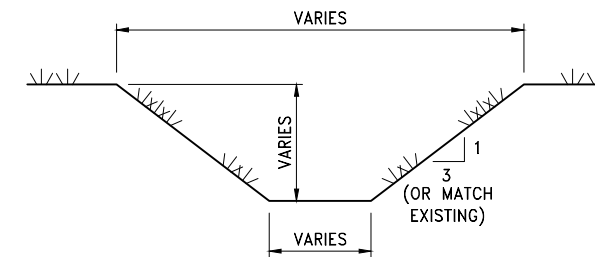

DRAINAGE CHANNEL NOTES:

1. ALL EXISTING DRAINAGE CHANNELS SHALL BE REPAIRED/REPLACED TO SAME OR BETTER CONDITION THAN FOUND.
2. EXISTING FLOW CAPACITY SHALL BE MAINTAINED OR EXCEEDED.
3. EXISTING MATERIAL MAY BE USED FOR CONSTRUCTION. ALL MATERIALS SHALL BE COMPACTED TO DENSITY REQUIREMENTS AS PER SPECIFICATIONS.
4. CONTRACTOR SHALL PROVIDE SMOOTH TRANSITIONS TO EXISTING SLOPES AND TERRAIN.
5. PAYMENT SHALL BE SUBSIDIARY TO OTHER ITEMS.

TYPICAL DRAINAGE CHANNEL DETAILS
NO SCALE



DRAWN BY: S.A.N.	REVIEWED _____ DATE : _____ FOR _____
DESIGNED BY: K.A.W./S.V.M.	REVIEWED _____ DATE : _____ FOR BANNER ASSOCIATES, INC.
CHECKED BY: D.G.O.	

REVISION	DATE	DESCRIPTION	BY	CK'D
1	6-13-17	ADDENDUM No. 1	SAN	SVM

BANNER

BANNER ASSOCIATES, INC. • CONSULTING ENGINEERS & ARCHITECTS
409 22nd Av S • P.O.Box 298 - Brookings, SD 57006 • (605)692-6342

LEWIS & CLARK REGIONAL WATER SYSTEM
TREATED WATER PIPELINE - MCWC SERVICE LINE

SCALE :	JOB NO :	DATE :
AS SHOWN	20000.35.01	MAY 17
SHEET NO. :		

TYPICAL DETAILS